

Emergency Aid Camp Infrastructure



Jerry Cans - Collapsible 10ltr



Manufactured from non toxic food grade LDPE, our foldable / collapsible Jerry cans are self supporting and ideal for emergency use. They are square shaped and intended for water collection and storage for individuals or family use. Moulded carry handles are incorporated into the design making them easy to transport by hand. The material is smooth finished with no sharp edges. Each jerry can has a screw top lid with distribution tap for ease of use.

Features

- Vacuum formed from virgin food grade LDPE material, suitable for drinking water use.
- Built-in handles wide enough for adult hands. Integrally moulded for extra strength and smoothed surface /joints for easy handling.
- The LDPE material is tested by a recognised laboratory for potable water purposes and drop tested to 2.5m while containing the maximum volume of water at 25C.
- Suitable for operating temperatures between -20C and +50C.
- The screw cap and 50mm neck are injection moulded using virgin polypropylene.
- Manufactured within ISO9001 guidelines and certified to ISO 14001 in respect of environmental disposal (toxin and pigment free polymers).
- The 10 litre foldable jerry can is FDA and EU approved for storage of drinking water.



Jerry Cans - Rigid 20 & 35ltr



Secure water containers manufactured from food grade plastic, available in both 20 and 35 litre capacities. Each container is fitted with a collared screw top for ease of refilling and a twist-off tap for spill free dispensing. The moulded handle design makes it ideal for transporting and storing water in and around the workplace, home or when travelling.



Butyl Products Ltd.

Lingfield House, 11 Radford Crescent, Billericay, Essex,
CM12 0DW, United Kingdom. T: +44 (0) 1277 653 281

E: enquiries@butylproducts.co.uk W: butylproducts.co.uk

Emergency Aid Camp Infrastructure

Jerry Cans - Collapsible 10ltr

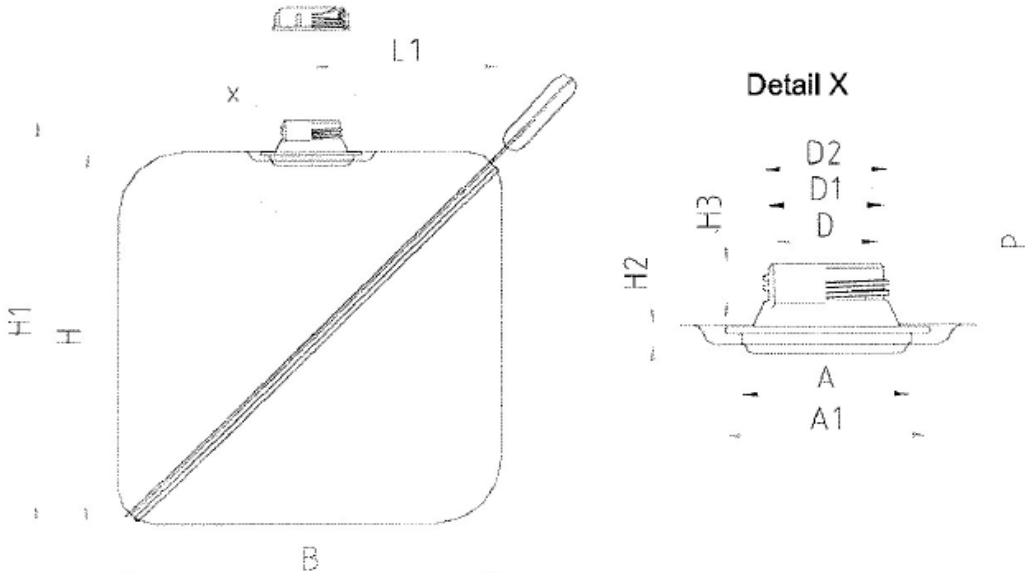

Description		Measurements	Tolerances
L	Length	228mm	not shown
B	Width	228mm	
H	Height	228mm	
H1	Height including neck	ca.247mm	Neck not extracted
H2	Cavity depth	6mm	
L1	Middle of neck	160mm	
D	Neck diameter	31.5mm	±0.15
D1	Thread inside diameter	34.6mm	±0.2
D2	Thread outside diameter	37.5mm	±0.2
H3	Thread height	11.1mm	
P	Pitch	3mm	
A	Diameter snap ring	51.5mm	±0.5
A1	Diameter snap ring	61.6mm	±0.5
	Number of starts	1	
	Closure torque in Nm	1.8	±0.2
	Nominal Capacity in litres	10	
	Brimful Capacity in litres	Refer to specification on box	



Butyl Products Ltd.

Lingfield House, 11 Radford Crescent, Billericay, Essex,
CM12 0DW, United Kingdom. T: +44 (0) 1277 653 281

E: enquiries@butylproducts.co.uk W: butylproducts.co.uk

